

8-4.5 mounting hole.
7.5 deep counterbore, depth 4.5 (back side)

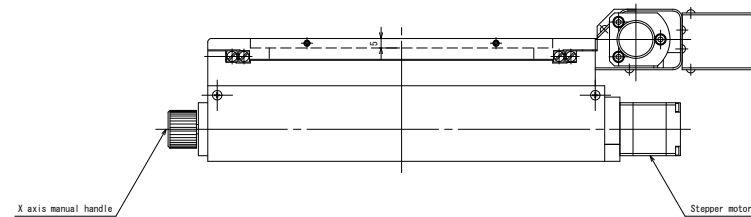
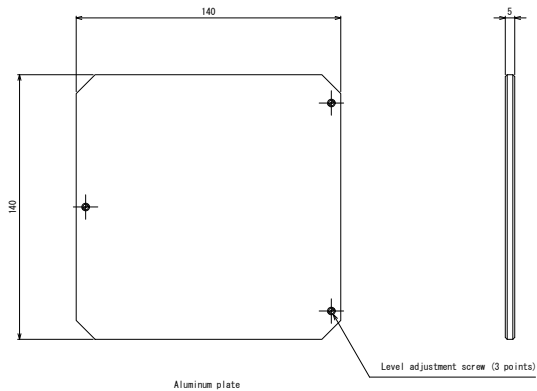
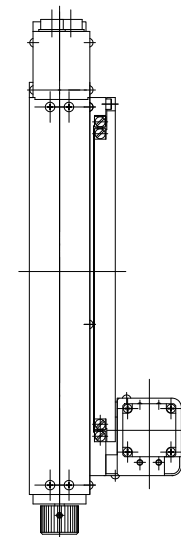
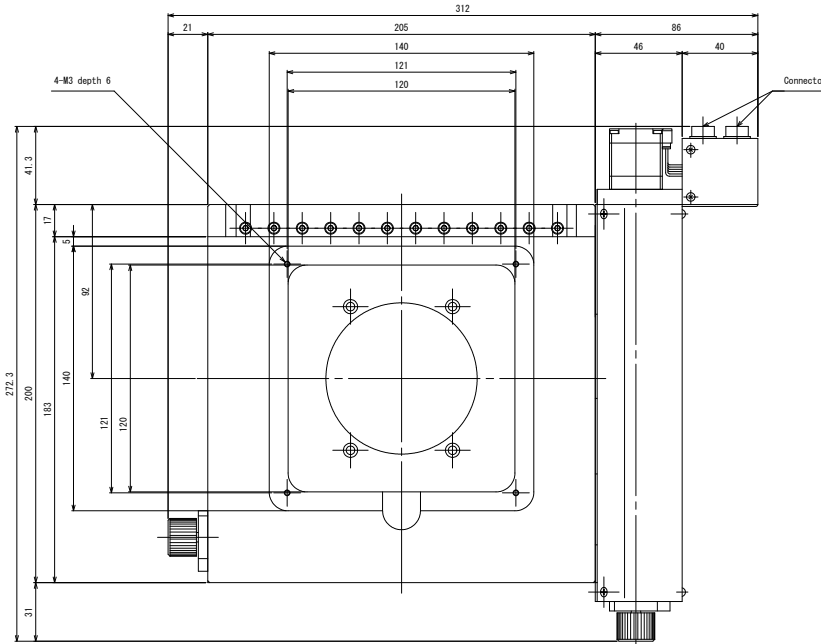
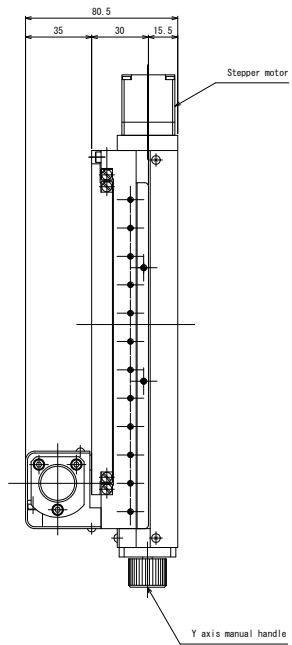
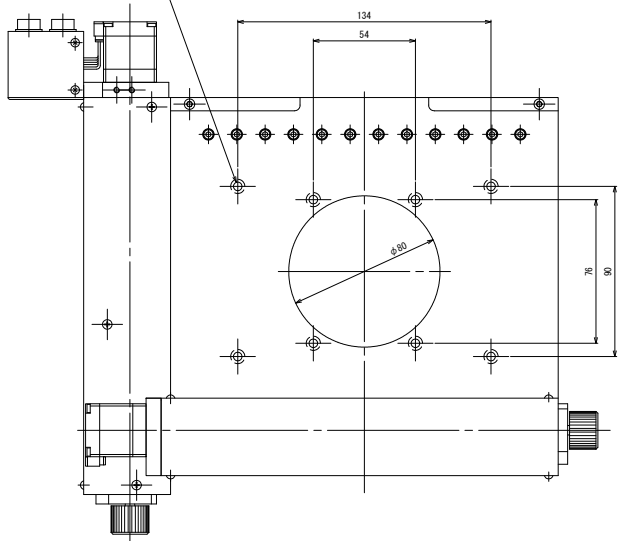

MSS-100D
Micro Scanning Stage
CHUO PRECISION INDUSTRIAL CO., LTD.
rev. -

*Mounting screw for adapter : Hexagon socket head cap screw M4, 4 screws